

I hereby certify that the within is a true and correct copy of Lease
No. 2416/100

.....
Mr Mark Webb
Director General

LEASE

LEASE NO 2416/100

**PART OF D'ENTRECASTEAUX NATIONAL PARK
RESERVE NO 36996**

**CONSERVATION AND LAND MANAGEMENT EXECUTIVE BODY
(LESSOR)**

and

**JOHN WEST, LEONIE WEST and KEVIN WEST
(LESSEE)**

Schedule

1. Lessor
2. Lessee
3. Leased Area
4. Term
5. Option to Extend
6. Rent
7. Permitted Use of the Leased Area
8. Minimum Public Liability Insurance Cover
9. Special Provisions

Terms and Conditions

1. Grant
2. Option to Extend
3. Rent
4. Rent Review
5. Outgoings
6. Building Work and Cleaning
7. Use of Leased Property
8. Fires and Environmental Protection
9. General Obligations and Restrictions
10. D'Entrecasteaux Huts Special Provisions
11. Indemnity and Insurance
12. Management of the Leased Area
13. Assignment and Subletting
14. Holding Over
15. Default
16. Lessee's Obligations on Termination
17. Costs and Expenses
18. Miscellaneous
19. Power of Attorney
20. Notices
21. Trustee Provisions
22. Interpretation

Schedule**1. Lessor**

The CONSERVATION AND LAND MANAGEMENT EXECUTIVE BODY – 17 DICK PERRY AVENUE KENSINGTON WA 6152

2. Lessee

JOHN WEST of 16 FRENCH STREET PEMBERTON WA 6260 and LEONIE WEST of 16 FRENCH STREET PEMBERTON WA 6260 and KEVIN WEST of PO Box 271 PEMBERTON WA 6260

3. Leased Area

HUT NUMBER 7 AT CALLCUP IN THE D'ENTRECASTEAUX NATIONAL PARK SHOWN DELINEATED ON THE ATTACHED LEASE DIAGRAM

4. Term

The period of 21 years from the Commencement Date to the Expiry Date

4.1 *Commencement Date:* 1 July 2017

4.2 *Expiry Date:* 30 June 2038

5. Option to Extend the Lease

5.1 *Option Period:* 21 years

6. Rent

For the first year of the Term, the rental is \$900.00 per annum.

For the second year of the Term, the rental is \$1,000.00 per annum then CPI Indexed annually in accordance with the Lease document (Excluding GST).

7. Permitted Use of the Leased Area

Short stay recreational accommodation

8. Minimum Public Liability Insurance Cover

\$10,000,000

9. Special Provisions

D'Entrecasteaux Huts Special Conditions

RECITALS

- A. Pursuant to Section 7(2) of the amended *Conservation and Land Management Act 1984* ("**the CALM Act**") the land in Reserve 36996 at D'Entrecasteaux National Park ("**the National Park**") is vested in the Conservation and Parks Commission.
- B. Pursuant to Section 100 of the CALM Act, the Chief Executive Officer (CEO) has power to lease the Land for the purpose of Recreation for a term as he/she thinks fit.
- C. Section 36 of the CALM Act allows for the Conservation and Land Management Executive Body ("**Executive Body**") to be established and to be governed by the CEO.
- D. Section 37 of the CALM Act allows for the Executive Body, as a body corporate, to perform functions of the CEO.
- E. The Lessee has applied to the Lessor for a Lease of that portion of the Land above described together with all buildings erections and other improvements now or hereafter erected thereon (collectively "**the Leased Area**").
- F. The Lessor has agreed to lease the Leased Area to the Lessee for the Term and at the rental respectively set out hereto and upon and subject to all the covenants agreements and stipulations contained in this Lease.
- G. Pursuant to Section 100(3) of the Act, the Lease shall be laid before each House of Parliament within 14 sitting days of its execution by all parties and will be incorporated into Hansard.

1. GRANT

1.1 Grant of Lease

Pursuant to Sections 36, 37 and 100 of the CALM Act, the Lessor leases the Leased Area to the Lessee for the Term subject to the terms and conditions of this Lease.

1.2 Quiet Enjoyment

For as long as the Lessee complies with the Lessee's obligations under this Lease, the Lessee may occupy and use the Leased Area during the Term without disturbance or interference by the Lessor except as permitted by this Lease or by law.

1.3 Termination by the Lessor or Lessee by Notice

Despite any other provision of this Lease, the Lessor or Lessee may mutually agree at any time to terminate this Lease by giving 12 months written notice of termination to either party.

2. OPTION TO EXTEND

2.1 Option Period

If a period is specified in item 5.1 of the Schedule, the Lessee has the option to extend this Lease for the Option Period, but only if:

- (1) the Lessee notifies the Lessor in writing that the Lessee wants to extend this Lease for that period at least 3 months before the Expiry Date (but not earlier than 12 months before that date); and
- (2) the Lessee is not in default under this Lease as extended when the option is exercised.

2.2 Rent During Option Term

The rent payable by the Lessee from the beginning of any extended Term of this Lease is to be the same rent payable immediately before the date of commencement of the extended Term unless that date is a rent review date, in which case the rent is to be reviewed with effect from that date, and the rent is subject to further review during the extended Term as provided in this Lease.

2.3 Default After Exercise of Option

If the Lessee defaults under this Lease after exercising an option to extend the Term of this Lease, the Lessor is not prevented from exercising any rights, including the right to terminate this Lease. If this Lease is terminated, the Lessor is not under any obligation to grant a Lease of the Leased Area to the Lessee for any extended Term.

2.4 Definitions

In this Lease:

Option Period means the period (if any) specified in item 5.1 of the Schedule.

3. RENT

3.1 Amount of the Rent

The annual rent payable under this Lease from the Commencement Date is the amount specified in item 6 of the Schedule.

3.2 Manner of Payment

The Lessee must pay the rent by equal annual instalments in advance. The first instalment is to be paid on the Commencement Date and subsequent instalments are to be paid on each anniversary of the Commencement Date. Rent payable for part of a year is to be proportionately adjusted on a daily basis. Rent is to be paid on receipt of a Lessor initiated invoice.

4. RENT REVIEW

4.1 CPI Rent Review

With effect from (and including) each date specified in this clause 4 as a "**CPI Review Date**", the rent must be reviewed on the basis that the reviewed rent is to be the higher of

- (1) the rent applying immediately before the relevant CPI Review Date; or
- (2) the amount calculated by using the following formula:

$$A = \frac{B}{C} \times D$$

Where:

- A = the amount of the reviewed rent which is payable from (and including) the relevant CPI Review Date.
- B = the last September quarter CPI Index Number published before the relevant CP Review Date.
- C = the last September quarter CPI Index Number published before the previous rent review date (or in the case of the first review, before the Commencement Date).
- D = the amount of the rent applying immediately before the relevant CPI Review Date.

4.2 Rent Review (Crown Land Rental)

With effect from (and including) each date specified in this clause as a Crown Land Rental Review Date, the Lessor can require that the rent be reviewed on the following basis.

If the Lessee has not agreed in writing to the amount of the reviewed rent proposed by the Lessor within one month of receiving such advice, the amount of the reviewed rent is to be the higher of:

- (1) the rent applying immediately before the relevant Crown Land Rental Review Date;
- (2) the Crown Land Rental Review for the Premises determined by a valuer licensed under the Land Valuers' Licensing Act:
 - (a) agreed to by each of the parties; or
 - (b) appointed by the President for the time being of the Australian Property Institute (WA Division) at the request of either party.

The Lessor must pay the fees charged by any valuer appointed under this Agreement to determine the Crown Land Rental for the Leased Area.

Crown Land Rent means the rent that a Lessee would be prepared to pay and an owner of the Leased Area would be prepared to accept taking into account:

- (1) the approved use and utility conferred under the Lease;
- (2) the nature of the Lessee. In this regard the Lessee is required to keep proper and audited books of account and these books of accounts for the current and past three years will be made available to the Lessor upon request for the purpose of assisting in the determination of the rent. Average management of the organisation will be assumed;
- (3) the provisions of this Lease;
- (4) the period which will elapse between the current Crown Land Rental Review Date and the next Crown Land Rental Review Date or, if there is not one, the termination of this Lease;
- (5) the full length of the Term and the benefit of any option to renew;
- (6) any improvement to the Leased Area but disregarding:
- (7) the consequences of any default by the Lessee of this Lease which may have adversely affected the condition, rental value or Crown Land rental of the Leased Area;
- (8) any part of the Term that has expired;
- (9) the value of the Lessee's Property and any goodwill created by the Lessee's business or activities to the Leased Area.

No delay by the Lessor in enforcing any review of the rent prevents the Lessor from requiring at any time that the rent must be reviewed with effect from the date for Crown Land Rental Review specified.

4.3 *Interpretation*

In this Lease:

CPI Review Date includes each anniversary of the Commencement Date after the first anniversary and Crown Land Rental Review Date.

Crown Land Rental Review Date means every fifth anniversary of the Commencement Date.

4.4 *Delay*

No delay by the Lessor in enforcing any review of the rent prevents the Lessor from requiring at any time that the rent must be reviewed with effect from the dates for review of the rent specified in this clause 4.

5. **OUTGOINGS**

5.1 *Rates and Taxes*

The Lessee must pay the Rates and Taxes either to the relevant Authority before those Rates and Taxes become overdue or, in the case of any Rates and Taxes imposed on the Lessor, to the Lessor as required by the Lessor whenever the Rates and Taxes become payable.

5.2 *Goods and Services Tax*

(1) **Definition**

GST means a goods and services tax or similar value added tax levied or imposed in Australia pursuant to the GST Act or otherwise on a supply.

GST Act means *A New Tax System (Goods and Services Tax) Act 1999* (Cth).

New Tax System Changes has the same meaning as in section 75AT of the *Trade Practices Act 1974* (Cth).

Tax Invoice includes any document or record treated by the Commissioner of Taxation as a tax invoice or as a document entitling a recipient to an input tax credit.

(2) **Adjustment for GST**

(a) Unless expressly included, the consideration for any supply made by the Lessor under or in connection with this Lease does not include GST.

(b) GST is payable on any supply of goods and services under this Lease.

(3) **Tax Invoices**

The Lessor must issue a Tax Invoice to the Lessee in respect of any supply of goods and services under the Lease.

(4) **Reimbursements**

If the Lessor is entitled under the Lease to be reimbursed or indemnified by the Lessee for a cost or expense incurred in connection with the Lease, the reimbursement or indemnity payment must not include any GST component of the cost or expense for which an input tax credit may be claimed by the Lessor.

5.3 Other Property Included

If Rates and Taxes are not assessed separately on the Leased Area but also on other property which includes the Leased Area, the amount which the Lessor can require the Lessee to pay is the same proportion of those Rates and Taxes as the area of the Leased Area bears to the area of the property the subject of the assessment.

5.4 Service Charges

The Lessee must pay all charges for all other Services which are imposed in respect of the Leased Area either to the supplier before those charges become overdue or, in the case of any such charges imposed on the Lessor, to the Lessor as required by the Lessor whenever the charges become payable.

6. BUILDING WORK, MAINTENANCE AND CLEANING

6.1 General Obligations

The Lessee must:

- (1) maintain the Leased Area in the condition as required by the Lessor (except for fair wear and tear); and
- (2) promptly repair any damage to the Leased Area; and
- (3) maintain the Lessee's Property (including signs) located on the Leased Area in good condition.

6.2 Building Work

If the Lessee constructs anything on the Leased Area or carries out any other work on the Leased Area, including work required by any Authority or any law, the Lessee must:

- (1) before carrying out the work, obtain the Lessor's written approval to the carrying out of the work, including if relevant, written approval of the plans and specifications for the work; and
- (2) comply with all relevant requirements of each Authority and all laws and applicable standards in relation to the work; and
- (3) carry out the work in a safe and proper manner; and
- (4) use only good quality materials; and
- (5) pay to the Lessor when the Lessor requests any reasonable expenses incurred by the Lessor in approving the work, including fees paid to architects, engineers, contractors or other advisors.

6.3 Maintenance of Leased Area

At the Lessee's own expense to keep and maintain the Leased Area and every part thereof and all buildings, structures, pavements, improvements, fixtures and fittings (both internal and external) comprised and situated therein and any addition thereto in good, safe and substantial repair order and condition, including the maintenance of

mechanical, electrical and electronic fixtures and fittings within the Leased Area in good repair and operating condition AND to promptly replace all broken and faulty electric light globes and tubes and all cracked and broken glass AND to keep all gardens and grounds forming part of the Leased Area well tended, neat, safe, in good order and condition and in accordance with the landscape design approved in writing by the Lessor.

6.4 *Provide Fixtures, Fittings and Chattels*

At all times during the Term to provide and install fixtures, fittings, mechanical, electrical and gas fixtures and fittings, floor coverings, plant, machinery, equipment, furniture, and other chattels within and to the Leased Area which are safe and of good quality and standard consistent with the standard expected of such a facility to enable the use of the Leased Area throughout the Term be in accordance with standards, principles and methods applicable from time to time.

6.5 *Cleaning*

The Lessee must:

- (1) keep the Leased Area clean and tidy and free of vermin; and
- (2) not store rubbish on the Leased Area and ensure all rubbish is contained in fly and rodent proof containers;
- (3) regularly remove rubbish accumulating on the Leased Area to a licensed rubbish disposal site; and
- (4) comply with the Lessor's reasonable directions in connection with cleaning and the disposal of rubbish in relation to the Leased Area.

6.6 *Specific Obligations*

Without limiting the preceding clause, the Lessee must :

- (1) dependant on the proximity of adjoining leased areas, keep the surrounds of the Leased Area for a maximum distance of 10 metres from the boundary clean and tidy and free of vermin as if the surrounds form part of the Leased Area;
- (2) not cause or allow any pollutant or contaminant material or substance over which the Lessee has control to be released into or affect the Leased Area; and
- (3) not dispose of rubbish from the Leased Area in any bins provided by the Lessor for public use in forest or nature conservation areas.

7. USE OF LEASED AREA

7.1 *Permitted Use*

The Lessee may only use the Leased Area for the Permitted Use unless the Lessor consents to another use.

7.2 Lessee's Own Enquiries

The Lessee has relied on the Lessee's own enquiries about how the Leased Area may be used and not on any representation from the Lessor. The Lessee has made the Lessee's own enquiries about :

- (1) the suitability of the Leased Area for any use to which it is to be put; and
- (2) all planning and any other requirements, prohibitions or restrictions applying to the Leased Area under any law or as a result of the requirements or orders of any Authority.

7.3 No Warranty by Lessor

The Lessor does not give any warranty of any kind that the Leased Area is suitable for any purpose for which the Lessee intends to use it. Any warranty in relation to the Leased Area which is implied by law is excluded to the extent that the law permits the warranty to be excluded.

7.4 The Lessor Not Liable

The Lessor is not liable to the Lessee and the Lessee will not make a claim against the Lessor in respect of any Liability resulting from any accident, death, injury, damage (including water damage), malfunction or other event in or affecting the Leased Area unless caused by the negligence of the Lessor or any employee, contractor or agent of the Lessor.

8. FIRES AND ENVIRONMENTAL PROTECTION

8.1 Fire Prevention

Without limiting any other provision of this Lease, the Lessee must in relation to the Leased Area promptly comply with :

- (1) the *Bush Fires Act 1954* and any other laws relating to the prevention and control of fires; and
- (2) all proper directions concerning fire prevention and control given to the Lessee by the Lessor or any Authority.

8.2 Fire Control

The Lessee must immediately :

- (1) notify the Lessor as soon as a fire is detected on the Leased Area;
- (2) take all reasonable and safe action which the Lessee is able to take to try to extinguish any unauthorised or uncontrolled fire on the Leased Area.

8.3 Authorised Fires

The Lessee must not do anything which causes or may cause a fire on the Leased Area unless the fire is:

- (1) not prohibited by law or by a direction of the Lessor or an Authority; and
- (2) the fire is not dangerous and is properly controlled so that it cannot become dangerous.

8.4 *Liability for Fires*

The Lessee is responsible for and must pay or reimburse the Lessor for all Liabilities as a result of any fire which starts on the Leased Area except where the fire:

- (1) was not caused by the Lessee's negligent or unlawful act or omission or the Lessee's default under this Lease; or
- (2) was started by a cause beyond the Lessee's reasonable control.

8.5 *Timber*

This Lease does not grant to the Lessee any rights to forest produce as defined in the amended *Conservation and Land Management Act 1984* and the provisions of Section 96(4) of that Act are hereby expressly excluded.

8.6 *Trees and Vegetation*

The Lessee must take all reasonable actions necessary to protect the trees and other vegetation growing on the Leased Area and take reasonable actions necessary to prevent, rectify or ameliorate any erosion, drift or movement of sand or soil from the Leased Area. Without limitation, unless required by clause 8.7, the Lessee may not cut down or damage or otherwise interfere with anything growing on the Leased Area without the written consent of the Lessor. The Lessee must also control declared plants and declared animals as defined in the *Agriculture and Related Resources Protection Act 1976*, in relation to the Leased Area, as required by that Act.

8.7 *Dangers or Threats to the Public and to the Leased Area*

The Lessee must:

- (1) regularly check the condition of trees and other vegetation on and adjacent to the Leased Area;
- (2) subject to approval being received from the Lessor, prune or remove any tree or other vegetation which is in a dangerous condition or which may threaten the safety of any person;
- (3) take adequate action to warn the public of any danger or threat constituted by any tree or other vegetation; and
- (4) generally take any measures necessary to prevent accidents and to protect the safety of the public on the Leased Area.

8.8 *Prevention of Disease*

The Lessee must comply with the Lessor's reasonable directions relating to the prevention of the spread of disease, particularly *Phytophthora Cinnamomi* (Jarrah dieback) in connection with the Leased Area, including prohibiting plant and soil being taken onto the Leased Area.

8.9 No Interference with Land

The Lessee acknowledges that the Leased Area may be environmentally sensitive and that the Lessor has a general duty to protect the environment. Accordingly, the Lessee must not, without first obtaining the consent of the Lessor, do anything to damage or otherwise interfere with the natural environment on the Leased Area, including:

- (1) removing rocks, earth, soil or other material from the Leased Area; or
- (2) clearing or removing trees or other vegetation from the Leased Area by any means; or
- (3) altering the contours of the surface of the Leased Area; or
- (4) depositing any earth fill or other similar materials on the Leased Area; or
- (5) altering the natural drainage on the Leased Area; or
- (6) introducing any new flora or fauna to the Leased Area; or
- (7) harming or endangering any flora or fauna on the Leased Area; or
- (8) anything else which in connection with the Leased Area may be harmful to the environment.

8.10 Notify the Lessor of Threats

The Lessee must immediately notify the Lessor if the Lessee becomes aware of anything which causes or could cause pollution (as defined in the *Environmental Protection Act 1986*) on or affecting the Leased Area.

8.11 Environmental Protection Laws

Unless otherwise stated, this Lease is not to be taken as exempting the Lessee from or limiting the obligation of the Lessee to comply with any law relating to the protection of the environment.

8.12 Environmental/Ecological Benchmarks

- (1) During the Term of this Lease the Lessee must achieve the benchmarks for the sustainability of the Lease and the continued use by the Lessee of the Leased Area which are itemised in Annexure 1 of the Sustainability Performance and Audit Schedule attached to and forming part of this Lease.
- (2) The Lessor shall have the right to monitor and audit the Lessee's performance, attainment and achievement of the requirements, obligations and standards specified in the Sustainability Performance and Audit Schedule at the times and in the manner specified in paragraph (3) of this clause.
- (3) During the Term, the Lessee may be audited annually or at the discretion of the Lessor against sustainability benchmarks in Annexure 1. The mechanism for auditing will be reviewed in consultation with the Lessee by December of each year of the Term.

- (4) The Lessee shall pay to the Lessor on demand the total cost of the annual audit (including auditor travel costs) charged to the Lessor by the auditor.
- (5) The Lessee must cooperate fully with the Lessor and the Lessor's personnel and auditors and assist them in and about the exercise of the Lessor's rights under the Sustainability Performance and Audit Schedule.
- (6) The Lessee acknowledges and agrees that the Lessor, the State and the Minister responsible for the *Conservation and Land Management Act 1984* are responsible for the administration of legislation with respect to conservation, the environment, land management, wildlife, flora and fauna.
- (7) The Lessor shall be entitled to amend, vary, modify, alter, add to or replace the whole or any part, item or provision of the Sustainability Performance and Audit Schedule, including by the addition of new items or benchmarks, at any time and from time to time by notice in writing to the Lessee in such manner and to such extent as the Lessor considers reasonably necessary or appropriate for the proper performance and observance of, and compliance with, its responsibilities under the legislation referred to in paragraph (6) above.
- (8) The Lessee shall observe, perform and comply with all the terms, conditions, provisions, items and benchmarks contained in the Sustainability Performance and Audit Schedule, as amended, varied, modified, altered, added to or replaced by the Lessor for the time being and from time to time, as if they were set out in full as covenants by the Lessee in the body of this Lease.
- (9) The provisions of the Sustainability Performance and Audit Schedule contained in Annexure 1 apply to and bind the Lessee on and from the Commencement Date. Each amendment, variation, modification, alteration, addition, replacement or new item (as the case may be) shall apply to and bind the Lessee on and from the date of service of notice thereof under paragraph (7) above.
- (10) In the event of any conflict or any inconsistency between a provision of this Lease and a provision of the Sustainability Performance and Audit Schedule (as amended, varied, modified or replaced from time to time) the provision of the Sustainability Performance and Audit Schedule shall be paramount and prevail to the extent of the conflict or inconsistency.

8.13 *Animals*

- (1) **Unwanted Animals**
Not to permit any domestic, exotic and feral animals (including birds and fish) onto the Leased Area or the National Park.
- (2) **Report**
To report to the Lessor the presence of any domestic, exotic or feral animal (including birds and fish) within the National Park which has been observed by the Lessee or its employees, contractors, agents and Guests.

(3) **Exclusion**

To cooperate with the Lessor to exclude from the Leased Area any person who is accompanied by an animal (provided that guide dogs for the blind and animals engaged in search and rescue may be admitted when under active supervision).

8.14 Asbestos Management

The Lessee shall at all times throughout the Term, ensure that it complies with all relevant Australian Standards and legal requirements which apply in relation to the management and removal of asbestos (if any) at or from the Leased Area.

9. GENERAL OBLIGATIONS AND RESTRICTIONS

9.1 Obligations

The Lessee must:

- (1) conduct the Lessee's business or activities in the Leased Area in a proper manner; and
- (2) comply with all relevant requirements of any Authority and every law in connection with the Leased Area and the Lessee's Property except where such requirements relate to work of a structural nature, unless rendered necessary by the nature of the Lessee's business or activities in the Leased Area; and
- (3) withdraw any 'subject to claim' caveat lodged to protect the Lessee's interest under this Lease at the termination, or on an assignment, of this Lease; and
- (4) promptly give the Lessor a copy of every notice from any Authority received by the Lessee relating to the Leased Area; and
- (5) immediately notify the Lessor if the Lessee becomes aware of anything which is a threat to the Leased Area and comply with the Lessor's directions for the purpose of protecting property or persons in the Leased Area; and
- (6) promptly inform the Lessor after becoming aware of any damage to the Leased Area; and
- (7) at all times during the Term to duly and punctually comply with, observe, carry out and conform to the provisions of all laws, Acts and statutes (State, Commonwealth or local) and all subsidiary legislation now or hereafter in force and all requirements and orders of any authority (statutory or otherwise) which affect the Leased Area or the use of the Leased Area or which impose any duty or obligation upon the owner or occupier of the Leased Area including the provisions of the Western Australia *Building Act 2011 and Building Regulations 2012* when conducting building operations within the Leased Area to ensure that any development works and all activities and operations of the Lessee within the Leased Area pursuant to this Lease meet the requirements of the *Building Act 2011 and Building Regulations 2012*. The Lessor may engage a consultant or expert to advise it whether or not the works to be carried out by the Lessee pursuant to this Lease meet those requirements.

9.2 Restrictions

In connection with the Leased Area, the Lessee must not (and may not permit anyone else to) except with the Lessor's consent:

- (1) cause damage to the Leased Area; or
- (2) store or use inflammable or explosive substances in the Leased Area except those normally used for any activity included in the Permitted Use but then only if they are stored in proper containers and used only in accordance with all relevant laws and the requirements of any Authority; or
- (3) use any facilities in or near the Leased Area, including toilets and drains, for any improper purpose; or
- (4) put any signs or advertisements outside the Leased Area or within the Leased Area, except as required by this Lease; or
- (5) permit any other person to carry on business on or from the Leased Area; or
- (6) use the Leased Area as a residence or for any activity which is dangerous, offensive, illegal or immoral or which is or may become a nuisance or annoyance to anyone; or
- (7) create any noise or other disturbance which interferes with the use by any other person of land which adjoins or is near to the Leased Area; or
- (8) abandon the Leased Area; or
- (9) create a security interest over this Lease in favour of any person or give another person any right to occupy or use the Leased Area; or
- (10) lodge an absolute caveat to protect the Lessee's interest under this Lease.

9.3 Local Government Act Requirements

Even though the *Local Government Act 1995* and subsidiary legislation, including any building regulations, may not apply in respect of the Leased Area, the Lessee must comply with that Act and subsidiary legislation as if it did apply, except to the extent that the Lessor waives any requirement. The Lessee must pay to the Lessor on request the fees or other costs charged to the Lessor by any consultant or other competent person who provides advice to the Lessor in relation to the Lessee's compliance with the Local Government Act and any subsidiary legislation.

10. D'ENTRECASTEAUX HUTS SPECIAL CONDITIONS

- (1) The Lessee shall prepare, keep and preserve a full record of visitation indicating, on a daily basis and in a form approved by the Lessor, the dates and number of Guests, employees, agents or contractors of the Lessee either occupying the hut or accessing the National Park, and shall make this record available to the Lessor by 31 July of each year during the Term.

- (2) The Lessee shall ensure that Guests, the general public and other visitors have access to and use of the huts held under this Lease in accordance with the Public Use Plan.
- (3) The Public Use Plan shall be reviewed annually during the Term, or any extended Term of this Lease.
- (4) The Lessor and Lessee shall mutually agree to amend, vary, modify, alter, add to or replace the whole or any part, item or provision of the Public Use Plan in accordance with paragraph (3) above.
- (5) The Lessee shall ensure that all vehicles brought into the hut area within the National Park and that all drivers comply with the *Road Traffic Act 1974*.
- (6) The Lessee shall ensure that the hut is maintained to the standard as set by the Shire of Manjimup for the Term of this Lease.
- (7) The Lessee shall install and maintain a fire extinguisher in workable condition in the hut.
- (8) The Lessee must maintain and display a Lessor approved emergency evacuation plan and guidelines on bushfire risks in the hut.
- (9) The Lessee will maintain a process for advertising the availability of the hut to the public and a schedule of fees Guests will be charged. Any changes to the advertising process or schedule of fees Guests will be charged must be approved by the Lessor.
- (10) The Lessee shall delineate and maintain a single access path between the hut and any outbuildings associated with the hut.
- (11) The Lessee shall ensure all waste water treatment and disposal is to the standard required by the Shire of Manjimup.
- (12) The Lessee shall keep the building and surrounds in a completely clean and tidy state, painted and maintained in a sound manner and in accordance with the requirements and standards as specified by the Shire of Manjimup in the hut condition report.
- (13) The Lessee is responsible for the clean up of any contamination, spill or other environmental incident that occurs as a result of negligence of the Lessee, the Lessees' employees, agents or contractors, or Guests, to the satisfaction of the Lessor.

11. INDEMNITY AND INSURANCE

11.1 *Indemnity*

The Lessee agrees to release and indemnify, and keep indemnified, the State of Western Australia (State), the Chief Executive Officer of the Department of Biodiversity, Conservation and Attractions (the department) and each of the employees, contractors and agents of the State or the department (**Indemnified Parties**) from and against all claims, demands, actions, suits, and proceedings (whether under the law of contract,

tort, a written law or otherwise); and damages, liabilities, losses, costs (including legal costs) and expenses, which may be made or brought against, suffered or incurred by any of the Indemnified Parties arising in any way from, or in connection with the conduct of the Lessee or any of its employees, agents and contractors or any of its Guests in relation to this Lease, except to the extent that any claims, actions, demands, suits, proceedings, damages, liabilities, losses or costs made or brought against, suffered or incurred by the Indemnified Parties are as a result of the Indemnified Parties' negligence:

- (1) on any lands to which the CALM Act applies;
- (2) or in relation to the activities the subject of this Lease;
- (3) or in relation to some risk, danger or hazard created, assumed or accepted whether or not the existence of that risk, danger or hazard was or ought to have been known to the Lessee.

11.2 Insurance

The Lessee must maintain with a reputable insurer:

- (1) public liability insurance of at least the amount specified in item 8 of the Schedule for each accident or event in the Leased Area; and
- (2) insurance for the Lessee's Property and any insurance required by law as a result of the Lessee's use of the Leased Area.

11.3 Variation of Insurance Amount

The Lessor may by notice to the Lessee at any time require the Lessee to increase the minimum cover for the Lessee's public liability insurance if in the circumstances it is reasonable for the cover to be increased.

11.4 Insurance Obligations

The Lessee must also:

- (1) pay each premium due under the insurance policies taken out by the Lessee before the due date and, when reasonably requested by the Lessor, provide evidence of payment; and
- (2) when reasonably requested by the Lessor, provide evidence of currency for each insurance policy certified by the insurer; and
- (3) immediately notify the Lessor if an event occurs which may give rise to a claim under any insurance or which could adversely affect it or if an insurance policy is cancelled; and
- (4) if required by the Lessor, ensure that the Lessor's interests are noted on the policy of public liability insurance.

11.5 Lessor's Insurance

Unless the Lessor consents, the Lessee must not:

- (1) do or allow anything to be done which could adversely affect any insurance taken out by the Lessor in connection with the Leased Area or which could increase the cost of obtaining that insurance; or

- (2) settle, compromise or waive any claim under any policy of insurance relating to the Leased Area.

11.6 *Environmental Indemnity*

The Lessee indemnifies and must keep indemnified the Lessor from and against all claims, proceedings, suits, writs, demands and expenses relating to, or in respect of, the remediation of contamination, pollution or environmental harm required under any Environmental Notice, by any law or by any Authority as a result of any contamination, pollution or environmental harm emanating on, or from, the Leased Area as a result of, or relating to, the use or occupation of the Leased Area by the Lessee.

11.7 *Contamination, Pollution or Environmental Harm*

- (1) The Lessor does not make any representation or warranty concerning the existence, non-existence, level or quantity of contamination, pollution or environmental harm on the Leased Area and adjoining land.
- (2) The Lessee relies on its own investigations concerning the existence, non-existence, level or quantity of contamination, pollution or environmental harm on the Leased Area and adjoining land.

12. MANAGEMENT OF THE LEASED AREA

12.1 *Managing Agent*

The Lessor may appoint a managing agent to manage the Leased Area and represent the Lessor in relation to this Lease. If the Lessor appoints a managing agent, the managing agent may exercise the rights and powers of the Lessor under this Lease. The Lessor may at any time vary or terminate the authority of the managing agent. Decisions of the Lessor override those of the managing agent if there is any inconsistency between them.

12.2 *Exercise of Rights Under the Amended Conservation & Land Management Act*

The Lessor reserves the right to enter the Leased Area at any time in order to exercise any right, power or authority which the Lessor has under the amended *Conservation and Land Management Act 1984*. The Lessee is not entitled to any compensation or to make any other claim against the Lessor for anything done by the Lessor on the Leased Area in the exercise of any right or Authority under that Act.

12.3 *Right to Enter*

The Lessor may after giving reasonable notice to the Lessee (or in an emergency, without notice) enter the Leased Area to do any one or more of the following things:

- (1) inspect the state of repair and condition of the Leased Area;
- (2) maintain or repair the Leased Area and equipment or facilities in the Leased Area;
- (3) carry out structural work to the Leased Area or any other work required by an Authority;
- (4) remove anything which is harmful or dangerous;

- (5) anything which should have been done by the Lessee but which has not been done properly;
- (6) anything else which the Lessor is required to do by law or is permitted to do under this Lease;

without affecting the Lessee's obligations under this Lease.

12.4 *Minimise Disruption*

If the Lessor does anything permitted by the preceding clause the Lessor must:

- (1) give the Lessee reasonable notice of the intended action before it is taken (except in an emergency); and
- (2) use its best endeavours to minimise disruption to the Lessee's business; and
- (3) make good any damage to the Lessee's Property (other than minor damage) caused by the Lessor.

12.5 *Dealing with the Leased Area*

The Lessor reserves the right to deal with the Leased Area by granting easements, licences or other rights or interests of any kind to any person over it at any time so long as this does not unreasonably interfere with the Lessee's use of the Leased Area for the Permitted Use. The Lessee is not entitled to any compensation or to make any other claim against the Lessor in relation to the proper exercise of any right given to another person by the Lessor. The Lessee is responsible for and indemnifies the Lessor against any Liability resulting from any claim made by a person to whom a right or interest has been granted by the Lessor in connection with any negligent act or omission of the Lessee or any default by the Lessee under this Lease.

13. ASSIGNMENT AND SUBLETTING

13.1 *Consent Required*

Unless the Lessor consents under the next clause, the consent which may not be unreasonably withheld, the Lessee may not assign this Lease or sublet the Leased Area.

13.2 *Requirements for Consent*

The Lessee may assign this Lease or sublet the Leased Area if the Lessor consents and if the Lessee:

- (1) complies with the next clause; and
- (2) supplies to the Lessor evidence acceptable to the Lessor that the proposed assignee or sublessee is able and qualified to use the Leased Area for the Permitted Use, is financially sound and has a good reputation; and
- (3) remedies any default under this Lease unless it has been waived by the Lessor; and

- (4) if requested by the Lessor, arranges for the proposed assignee or sublessee to obtain from one or more persons, as reasonably nominated by the Lessor, a guarantee of the obligations under this Lease to be assumed by the proposed assignee or sublessee in a form prepared or approved by the Lessor's solicitors.

13.3 *Obligations on Assignment or Sublease*

If the Lessee assigns this Lease or sublets the Leased Area, the Lessee must:

- (1) deliver to the Lessor, before the date that the proposed assignment or sublease is to take effect, a completed agreement in the form of a deed prepared or approved by the Lessor's solicitors, by which the proposed assignee or sublessee agrees with the Lessor to be bound by this Lease as from the date the assignment or sublease takes effect; and
- (2) pay to the Lessor on request the Lessor's expenses, including legal costs:
 - (a) incurred in making reasonable enquiries about the proposed assignee or sublessee; and
 - (b) in connection with the preparation, completion and stamping of the assignment or sublease documents and any other related documents, (including the stamp duty on those documents).

13.4 *Lessee Remains Liable*

- (1) The Lessee remains fully liable under this Lease even if the Lessee assigns this Lease or sublets the Leased Area or gives any right in relation to this Lease or the Leased Area to any other person.
- (2) The Lessee may apply to the Lessor to be granted an exemption to clause 13.4(1), subject to conditions stated by the Lessor at the time.

13.5 *Change in Control*

If the Lessee is a company, and there is a change in control of the Lessee the Lessor may require the Lessee to obtain from the persons who have acquired control, as reasonably nominated by the Lessor, a guarantee of the Lessee's obligations under this Lease in a form prepared or approved by the Lessor's solicitors. If the Lessee is a subsidiary company a change in control includes a change in control of its holding company.

In this clause:

- (1) **company** does not include a company which is listed on the Australian Stock Exchange or is wholly owned by such a company; and
- (2) **control** means control of the composition of the board of directors or control of more than 20% of the shares with the right to vote at general meetings; and
- (3) words defined in the Corporations Law have the meanings given to them by that Law.

13.6 Exclusion of Statutory Provisions

The provisions of sections 80 and 82 of the *Property Law Act 1969* do not apply to this Lease.

13.7 Fees

The Lessee must reimburse the Lessor on request for all fees paid by the Lessor to any agent or consultant engaged by the Lessor in connection with a proposed assignment or sub-letting by the Lessee.

14. HOLDING OVER

If the Lessor consents to the Lessee continuing to occupy the Leased Area after the Expiry Date or after the end of any extended Term, the Lessee is a monthly Lessee of the Leased Area and:

- (1) the monthly tenancy may be terminated by either party giving to the other at least one month's notice which may expire on any day; and
- (2) the rent is the same rent payable immediately before the Expiry Date or after the end of any extended term; and
- (3) all the other provisions of this Lease apply to the monthly tenancy except any option to extend this Lease.

15. DEFAULT

15.1 Re-entry

The Lessor may terminate this Lease by notice to the Lessee or by re-entering the Leased Area if:

- (1) the Lessee repudiates this Lease; or
- (2) the Lessee abandons the Leased Area; or
- (3) the Lessee ceases to use the Leased Area for the Permitted Use other than for a temporary period; or
- (4) the rent or any other money payable by the Lessee is unpaid for longer than 3 months after it is due to be paid; or
- (5) the Lessee is in default under this Lease and, if the default can be remedied, the Lessee has not remedied the default within 3 months after receiving a notice from the Lessor specifying the default and requiring it to be remedied; or
- (6) an Insolvency Event occurs; or

Except for the notice given under subclause (5) and except for any notice otherwise required by law the Lessor does not need to give notice to the Lessee before re-entering the Leased Area.

15.2 Essential Terms and Damages

Every obligation of the Lessee under this Lease:

- (1) to pay money; or
- (2) not to do something without the Lessor's consent; or
- (3) relating to damage to the Leased Area or to the state of repair or condition of the Leased Area,

is an essential term of this Lease. (This clause does not prevent other obligations being essential terms).

If the Lessee defaults by not performing or complying with any obligation which is an essential term, the Lessor is entitled to recover damages for losses over the whole Term, including losses caused by the non-payment of money by the Lessee over that period, even if this Lease is terminated by the Lessor as a result of the Lessee's default before the Expiry Date.

This clause is not to be taken as relieving the Lessor of any duty to mitigate losses which is imposed by law.

15.3 Right to Damages Not Affected

The Lessor's right to recover damages is not affected if:

- (1) the Lessor accepts the Lessee's repudiation of this Lease; or
- (2) the Lessor terminates this Lease by notice or re-entry; or
- (3) the Lessee has abandoned the Leased Area; or
- (4) there is a surrender of this Lease by law.

15.4 Interest on Overdue Money

The Lessee must pay interest on any money which is not paid by the due date. Interest is to be the higher of:

- (1) 15%; or
- (2) the current reference rate or other base rate charged by the Commonwealth Bank on overdraft loans of less than \$100,000 plus 2%,

and is to be calculated on a daily basis from the due date until the money is paid. The interest is to be paid when requested by the Lessor.

15.5 Acceptance of Rent or Mitigation

The acceptance of rent or other money owing under this Lease or an attempt by the Lessor to mitigate losses is not to be taken as a waiver of a default by the Lessee under this Lease or a surrender by law.

16. LESSEE'S OBLIGATIONS ON TERMINATION

16.1 Lessee to Move Out

The Lessee must move out of the Leased Area and remove all the Lessee's Property from the Leased Area by the end of the Term except that if this Lease is terminated before that date, the Lessee must move out and remove the Lessee's Property as soon as reasonably possible after this Lease is terminated.

16.2 Abandonment of Lessee's Property

- (1) If the Lessee does not remove all the Lessee's Property when the Lessee has to move out of the Leased Area the Lessee is deemed to have abandoned the Lessee's Property; and
- (2) If the Lessee's Property is found to contain asbestos or is of no value to the Lessor, then the Lessee shall be responsible for all costs incurred by the Lessor to remove the Lessee's Property and rehabilitate the Leased Area; or
- (3) If the Lessee's Property remaining in the Leased Area is of value to the Lessor and does not contain asbestos, the Lessee's Property will become the property of the Lessor.

16.3 Risk

The Lessee's Property is at the Lessee's risk at all times before and after the termination of this Lease.

16.4 Damage Caused by Moving Out

The Lessee must repair any damage to the Leased Area caused by moving out of the Leased Area or removing the Lessee's Property.

16.5 Reinstatement

If the Lessee has made any improvements or alterations to the Leased Area or carried out any work on the Leased Area or done anything else to change the Leased Area if the Lessor requires, the Lessee must reinstate the Leased Area before the end of the Term so that the Leased Area is returned to the condition it was in before the improvements or alterations were made, or the work carried out or the other changes were made. The Lessee's obligations under this clause include removing any building or other structure erected in the Leased Area by the Lessee unless the Lessor agrees otherwise or unless this Lease provides otherwise.

17. COSTS AND EXPENSES

17.1 Costs and Expenses

The Lessee must pay or reimburse the Lessor on request for all the Lessor's costs and expenses (including legal costs and expenses) in relation to:

- (1) arranging for any survey or demarcation drawing necessary to identify the Leased Area; and

- (2) negotiating, preparing, signing and stamping of this Lease and any document assigning, varying or surrendering this Lease; and
- (3) enforcing any right under this Lease including giving a notice of default under section 81 of the Property Law Act; and
- (4) any default by the Lessee which causes loss to the Lessor; and
- (5) giving any consent or approval under this Lease.

17.2 Duties and Fees

The Lessee must pay or reimburse the Lessor on request for all stamp duty and fees (including fines and penalties attributable to the Lessee) payable in connection with this Lease.

18. MISCELLANEOUS

18.1 Remedies Cumulative

The rights, powers and remedies in this Lease are in addition to the rights, powers and remedies provided by law independently of this Lease.

18.2 Accrued Rights

The termination of this Lease for any reason does not affect the rights of the Lessor in relation to a default by the Lessee before termination.

18.3 Severance

If any part of this Lease or the application of that part to any person or circumstance is or becomes unenforceable, the other provisions of this Lease are not affected but continue to be enforceable.

18.4 Payments

The Lessee must make all payments under this Lease without set-off, counterclaim or deduction. Payments by the Lessee under this Lease are to be made to the Lessor or any other person nominated by the Lessor. The Lessor need not make a demand for payment of any amount required to be paid by the Lessee under this Lease unless required by law. If this Lease does not specify when a payment is due, it is due within 14 days after the Lessor requests payment.

18.5 Transfer of Land Act

The covenants and powers implied in every lease made under the *Transfer of Land Act 1893* are implied in this Lease, whether registered under that Act or not, except:

- (1) to the extent that they are modified by this Lease; and
- (2) the implied covenant set out in section 92(ii), which is excluded.

18.6 Cost of Complying with Obligations

Unless otherwise stated in this Lease, the Lessee must pay the cost of performing or complying with every obligation of the Lessee under this Lease.

18.7 The Lessor Can Comply

If the Lessee does not perform or comply with an obligation under this Lease the Lessor may do what is necessary for the obligation to be performed or complied with. The Lessee must reimburse the Lessor for any reasonable costs or expenses incurred in ensuring the Lessee's obligations are performed or complied with.

19. POWER OF ATTORNEY

The Lessee for valuable consideration irrevocably appoints the Lessor and every senior officer of the Lessor (jointly and severally) the Lessee's attorney for the purpose of:

- (1) withdrawing any caveat which the Lessee is obliged to withdraw but does not; and
- (2) doing anything else the Lessee is obliged to do but does not do.

In this clause "**senior officer**" means every person designated by the Lessor as a senior officer.

20. NOTICES

20.1 Form and Address

A notice or other communication in connection with this Lease must be in writing and may be signed by the relevant party or its solicitors or agents.

The notice or other communication may be:

- (1) left at or posted to the address of the addressee as set out in the Schedule or any other address notified to the sender as an address for the giving of notices; or
- (2) sent by facsimile transmission to any facsimile number used by the addressee.

20.2 Receipt

Unless a later time is specified in it, a notice or other communication takes effect from the time it is taken to be received, which is:

- (1) if left at the address of the addressee, the next Business Day after the day it is left;
- (2) if posted, on the third Business Day after posting; and
- (3) if sent by facsimile transmission, on the next Business Day after the facsimile was sent.

21. TRUSTEE PROVISIONS

If the Lessee has entered into this Lease in the capacity of trustee whether or not the Lessor has any notice of the trust, the Lessee :

- (1) is taken to enter into this Lease both as trustee and in the Lessee's personal capacity and acknowledges that the Lessee is personally liable for the performance of the Lessee's obligations under this Lease; and
- (2) will take any action necessary to ensure the assets of the trust are available to satisfy any claim by the Lessor for any default by the Lessee; and
- (3) will assign to the Lessor any right of indemnity the Lessee has against the assets of the trust to the extent of the liability of the Lessee under this Lease; and
- (4) warrants that the Lessee has the power and authority under the terms of the trust to enter into this Lease.

22. INTERPRETATION

22.1 Definitions

In this Lease:

Authority means any governmental or public authority of any kind.

Business Day means a day on which banks are open for business in Perth other than a Saturday or a Sunday.

CALM Act means the *Conservation and Land Management Act 1984* as amended.

Expiry Date means the date in item 4.2 of the Schedule.

Insolvency Event means the happening of any of the following events in relation to the Lessee:

- (1) the Lessee is unable to pay all the Lessee's debts as and when they become due and payable or the Lessee has failed to comply with a statutory demand as provided in section 459F of the Corporations Law, or the Lessee is deemed to be unable to pay the Lessee's debts under section 585 of the Corporations Law;
- (2) a meeting is convened to place the Lessee in voluntary liquidation or to appoint an administrator;
- (3) an application is made to a court for the Lessee to be wound up;
- (4) the appointment of a controller (as defined in section 9 of the Corporations Law) of any of the Lessee's assets;

- (5) the Lessee proposes to enter into or enters into any form of arrangement (formal or informal) with the Lessee's creditors or any of them, including a deed of company arrangement; or
- (6) the Lessee becomes an insolvent under administration, as defined in section 9 of the Corporations Law.

Leased Area means the area of land described in item 3 of the Schedule and includes all buildings and other improvements on that area of land unless this Lease provides that ownership of any buildings or improvements constructed by the Lessee on the Leased Area remains in or vests in the Lessee.

Lessee means the person or persons named in item 2 of the Schedule and includes the Lessee's successors and an assignee, a sublessee or any other person having a right to possess, use or occupy the Leased Area.

Lessee's Property means any buildings, fences, plant or equipment or other property which the Lessee constructs on or brings in to the Leased Area.

Lessor means the statutory body described in item 1 of the Schedule and includes the Lessor's successors and an assignee of the reversion and, where the context permits, any person authorised by the Lessor to do any act on behalf of the Lessor for the purposes of this Lease, including a managing agent.

Liability includes any obligation to pay money or other loss, cost or expense of any kind.

Guests means those persons who utilise the Leased Area with the approval of the Lessee.

Permitted Use means the use described in item 6 of the Schedule.

Public Use Plan means the document approved by the Lessor which defines the nature and scope of public use of the Leased Area so as to meet the demand for public use and is shown as Annexure 2 to this Lease.

Rates and Taxes means any rate, tax, levy or any other charge imposed at any time during the Term of the Lease by any State, local or Federal governmental body, Authority, department or instrumentality or any other Authority of any kind, in relation to the supply or use of the Leased Area or any thing under or in connection with the Lease.

Term means the period referred to in item 4 of the Schedule.

22.2 Interpretation

In this Lease, unless the contrary intention appears:

- (1) a reference to the Lessee includes the Lessee's employees, agents, contractors, sublessees, Licensees, customers and any other person who is in the Leased Area with the Lessee's permission (direct or implied);
- (2) a reference to a statute, code or other law includes regulations and other instruments under it and consolidations, amendments, re-enactments or replacements of any of them occurring at any time before or after the Commencement Date;

- (3) the singular includes the plural and vice versa;
- (4) the word "person" includes a firm, a body corporate, an unincorporated association or an Authority;
- (5) an obligation, representation or warranty:
 - (a) in favour of 2 or more persons is for the benefit of them jointly and severally; and
 - (b) on the part of 2 or more persons binds them jointly and severally;
- (6) each obligation of a party to this Lease has effect as a covenant given in favour of the party who may enforce the obligation;
- (7) if a period of time is expressed to be calculated from or after a specified day, that day is not included in the period;
- (8) a reference to a day is a reference to the 24 hour period commencing at midnight;
- (9) a reference to a month is to a calendar month and a reference to a year is a calendar year;
- (10) if the word 'including' or 'includes' is used, the words: "without limitation" are deemed to immediately follow;
- (11) a reference to the termination of this Lease includes the expiry of the Term; and
- (12) a reference to the Term in relation to any obligation of the Lessee is to be taken as including a reference to any period during which the Lessee occupies or uses the Leased Area with the Lessor's consent.

22.3 *Schedule*

All the provisions in the Schedule at the front of this Lease are incorporated in and form part of this Lease.

22.4 *This Lease*

A reference to this Lease includes:

- (1) everything forming part of this document; and
- (2) any agreed changes to this document which are recorded in a separate document.

ANNEXURE 1

SUSTAINABILITY PERFORMANCE AND AUDIT

DEFINITIONS

In this Annexure, unless the context otherwise requires:

BEC means Build Environment Criteria.

Department means the Department of Biodiversity, Conservation and Attractions.

NEC means Natural Environment Criteria.

SEC means Social Environment Criteria.

LESSEE SPECIFIC SUSTAINABILITY PERFORMANCE

SITE DESIGN AND LAYOUT (BEC)

1. The Lessee will ensure that any improvements, additions, modifications, alterations or changes to the hut on the Leased Area:
 - i. Comply with and are maintained according to these Lease conditions; and
 - ii. Comply with and are maintained to the Shire of Manjimup health standards and receive the approval firstly of the Lessor and then the Shire of Manjimup.

MAINTENANCE OF NATURAL ECOLOGY (NEC)

2. Within the first year of the Commencement Date and for the duration of the Term, the Lessee will develop and implement a weed management program to include:
 - i. Introduction and monitoring compliance with protocols for the prevention of the introduction of non-endemic plant species (including inspection and wash down of vessels, inspection of supplies at delivery and storage phases);
 - ii. Education of Guests, employees, agents and contractors in the inspection for and disposal of weed seeds;
 - iii. Annual weed monitoring (including formal assessment of weed status) of the area; and
 - iv. Weed eradication using methods approved by the department.
3. The Lessee will:
 - i. Plant only indigenous vegetation in or around the area after consultation and approval of the department's Senior Ranger prior to planting any vegetation;
 - ii. In consultation with the department's Senior Ranger, rehabilitate areas within and adjacent to the area and revegetate areas not utilised for structures, services and facilities or access areas;
 - iii. Assist the department in its programs of weed eradication and land rehabilitation of the area (planting and maintenance of endemic species) at the request of the department's Senior Ranger;
 - iv. Not allow its own pets or those of its employees, agents, contractors or Guests into the National Park and include this on verbal and written promotional material; and

- v. Not feed or allow any employee, agent, contractor or Guests to feed animals in the National Park and encourage the containment of rubbish and food scraps in sealed bins.

EROSION, SOIL LOSS, COMPACTION AND VEGETATION DAMAGE (NEC)

- 4. The Lessee will ensure that the accommodation component of the Lease is limited to the footprint only and that no disturbance to vegetation or landforms outside the designated area occurs through the provision of sensitive design, education or signage. The Lessee will control grass growth within the area to the satisfaction of the department's Senior Ranger.
- 5. The Lessee will monitor and manage (including to take actions to prevent, limit and remedy) soil loss, compaction and erosion in the area. The Lessee will ensure that:
 - i. Site design and layout controls pedestrian impact and avoids compaction under trees;
 - ii. Minimal loss and clearing of understorey vegetation occurs and that revegetation and rehabilitation of the site occurs, and in consultation with the department's Senior Ranger;
 - iii. All pedestrian paths are defined with stable materials; and
 - iv. In the event of any soil loss, compaction or erosion of the area, remedial action is undertaken immediately with the approval of the department's Senior Ranger.

WATER USE (NEC) & WASTE WATER (BEC)

- 6. The Lessee will:
 - i. Ensure effluent and waste water is treated to best possible standards before leaching occurs in accordance with the Shire of Manjimup requirements and approvals; and
 - ii. Ensure that only sub surface disposal of treated waste water occurs.

SOLID WASTE (NEC) & WASTE STORAGE AND DISPOSAL (BEC)

- 7. The Lessee will:
 - i. Develop a collection process for recyclable materials;
 - ii. Store and transport waste in a manner that prevents vermin, odour and spillage; and
 - iii. Ensure that all inorganic solid waste is transported out of the National Park as required or as directed by the department's Senior Ranger. Waste must be disposed of at a licensed facility and where possible at a recycling facility.

TOILET FACILITY STANDARDS (BEC)

- 8. The Lessee will:
 - i. ensure all toilet facilities are maintained to the standard as specified by the Shire of Manjimup in the hut condition report;
 - ii. ensure all waste water disposal is in accordance with the Shire of Manjimup specifications for the area.

ENERGY CONSUMPTION (NEC) & METHOD OF ENERGY CONSUMPTION (BEC)

9. The Lessee will:
- i. Within the first year of the Term and for the duration of the Lease, develop and implement a policy to minimise and annually reduce non-renewable energy consumption, maximising use of renewable energy sources;
 - ii. Only use energy efficient appliances and lighting equipment and minimise the use of high energy use appliances;
 - iii. By the fifth year of the of the Term, 50% of all power being used in the operations, will be from renewable energy with up to an average of six (6) hours per day, averaged over a 12 month period, of use from a back up generator; and
 - iv. By the tenth year of the Term, 75% of the power is to be from renewable energy, with up to an average of four (4) hours per day, averaged over a 12 month period, of use from a back up generator.

ENVIRONMENTAL STEWARDSHIP (NEC)

10. The Lessee will:
- i. Minimise, manage and monitor the operation's environmental impact;
 - ii. Keep records and supply information to the department on any matter it requests;
 - iii. Report incidence of damage or risk within the National Park;
 - iv. Actively and cooperatively participate in any research associated with the operation or the National Park;
 - v. Support and assist the department with the rehabilitation and repair of roads and parking infrastructure within the area; and
 - vi. Support the department in emergency situations with the provision of resources at the request of the department's Senior Ranger.

LIGHT SPILL (NEC)

11. The Lessee will:
- i. Except in an emergency or with the approval of the department's Senior Ranger, not use floodlights in the Leased Area;
 - ii. Provide a lighting plan for approval by the department's Donnelly District Manager to ensure natural ambient light conditions prevail 10 metres outside the site.

NOISE LEVELS (NEC)

12. The Lessee will:
- i. Commit to minimising noise by operating generators for a maximum of six (6) hours per day, averaged over a 12 month period, with a commitment to reduce generator use time to a maximum of four (4) hours per day, averaged over a 12 month period, by the tenth year of the Term of the Lease, keep a log of its operation and not operate it after 2130;
 - ii. Within the first year of the Lease and for the duration of the Lease, implement noise reduction measures on generators.

CHEMICAL/FUEL STORAGE AND HANDLING (BEC)

13. The Lessee will:

- i. Display a commitment to using environmentally sensitive products wherever possible;
- ii. At all times, store chemicals in a designated locked structure and store fuel in a designated signed location;
- iii. Maintain a register of chemicals and fuels on site (quantity, use and storage), management requirements and any spill events;
- iv. Ensure signage and storage complies with Australian Standards and the *Dangerous Goods Safety (Storage and Handling of Non-explosives) Regulations 2007* and the Worksafe Guidance Note;
- v. At all times, have spill response equipment and spillage recovery equipment in place in accord with the *Dangerous Goods Safety (Storage and Handling of Non-explosives) Regulations 2007*; and
- vi. Dispose of chemicals outside the National Park in an environmentally appropriate manner and as required by law.

CULTURALLY SENSITIVE BEHAVIOUR (SEC)

14. Within the first year of the Lease and for the duration of the Lease, the Lessee will develop and deliver educational and interpretation materials (where appropriate) for the Lessee's employees, agents, contractors and Guests on the following matters (including on-site verbal and written communications and signage) and incorporate these into an information manual:
 - i. Major environmental issues at the area and those affecting the National Park (erosion, soil loss, compaction and vegetation damage);
 - ii. Local ecological conditions, Indigenous culture and low impact nature based tourism principles developed in consultation with local Indigenous people;
 - iii. Responsible behaviour in the natural environment developed in consultation with the department's Donnelly District;
 - iv. Waste management, minimising packaging in the National Park and solid waste reduction issues, initiatives and methods;
 - v. Waste water minimisation;
 - vi. Recycling initiatives and appropriate use of toilets and ablution facilities to minimise water use;
 - vii. Culturally sensitive behaviour; and
 - viii. Any risks in the National Park and all safety rules.

SAFETY EQUIPMENT AND PROCEDURES (SEC)

15. The Lessee will have, at all times:
 - i. Access to communal fully functioning emergency communication equipment;
 - ii. Access to communal basic search and rescue, incident and emergency protocols, contingency plans for emergency situations and a management plan for high risk activities;
 - iii. First aid equipment on site;
 - iv. Visible signage indicating the location of fire extinguishers, fire blanket and first aid kit.

CONTENT OF MARKETING MATERIAL (SEC)

16. On all promotional material the Lessee will provide background information on sustainability principles in natural areas, and will provide accurate descriptions of all features of the facilities and level of service, and park features.

ANNEXURE 2

Public Use Plan Agreement

Mr John West

Hut 7 Callcup

Licence 2416/101

1. The plan to remain in place until 30 November 2018.
2. An annual meeting will be held to discuss any implementation issues.
3. The public use plan is subject to the issue of a recreational hut lease by the Department of Parks and Wildlife.
4. Unless varied by agreement with the Department of Parks and Wildlife I agree to the following:
 1. The hut will be made available for a minimum of 60 days per year in segments of not less than 3 consecutive nights at any one time. I will manage the timeframes for when the hut will be available for public use.
 2. The huts to be made available via public accessible booking service as agreed by the Department of Parks and Wildlife, District Manager, Donnelly District.
 3. The hut will be rented for up to \$250.00 per night.
5. The Public Use Plan will be implemented within 30 days of lease documents being issued by the Department of Parks and Wildlife.
6. The level of public use will comply with Public Health Act and Building Code of Australia standards and requirements as advised by the Shire of Manjimup with report to the Department of Parks and Wildlife, District Manager, Donnelly District by the 31 October annually.
7. The plan is to be formally reviewed with the Department of Parks and Wildlife, Donnelly District, by November 2018.

Signed



17 May 2017

J. Hillard
18/5/17

*it will be advertised
via public noticeboard at
the Pemberton Post office and
on site signage at the hut.*

J. Hillard
18/5/17

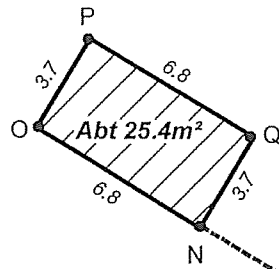

D'Entrecasteaux National Park
A 36996
313

Point	Northing	Easting
A	397455.73	6168083.83
B	397448.83	6168086.22
C	397452.11	6168095.66
D	397455.23	6168094.58
E	397457.75	6168101.86
F	397464.65	6168099.47
G	397462.71	6168093.90
H	397459.60	6168094.98
J	397458.62	6168080.38
K	397466.60	6168078.50
L	397465.32	6168073.05
M	397457.34	6168074.93
N	397442.02	6168111.41
O	397436.21	6168114.94
P	397438.13	6168118.10
Q	397443.94	6168114.57

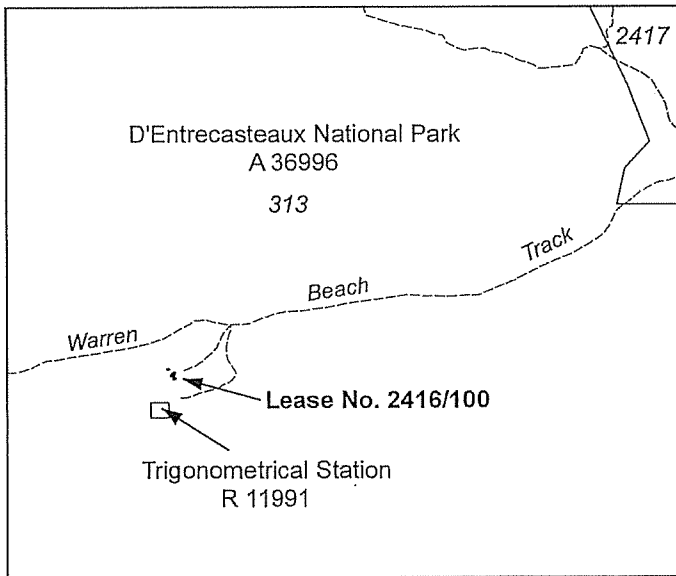
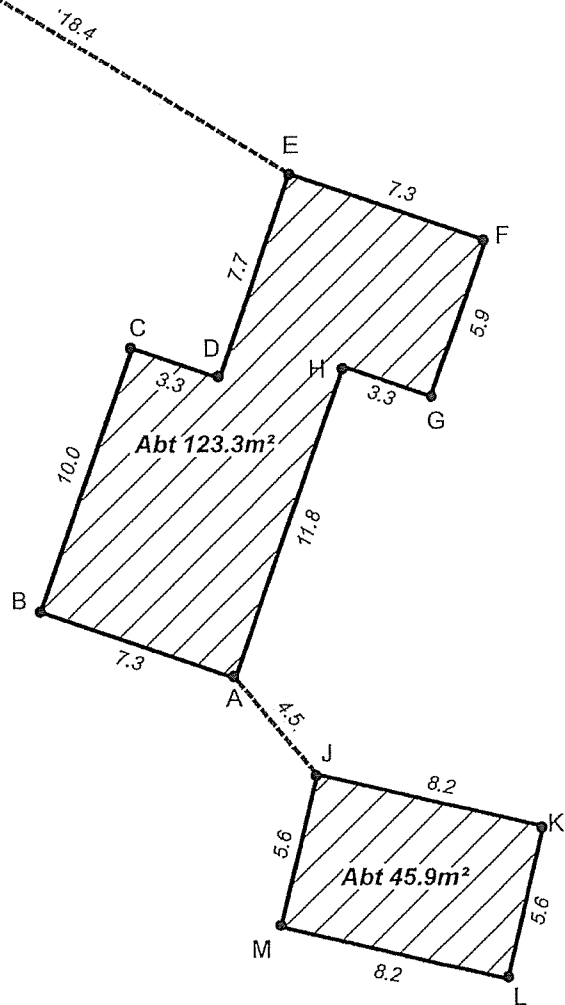

Note:
dimensions and coordinates calculated from data sent
from Donnelly District Office Parks and Wildlife Service.

LEASE No. 2416/100			LEASE PLAN APPROVAL		 SCALE: 1:250
LESSEE	JOHN WEST, LEONIE WEST and KEVIN WEST		LESSEE	<i>[Signature]</i>	
			WITNESS	<i>[Signature]</i>	
DBCA REGION	WARREN	AREA	Abt 194.6 m ²		
DBCA DISTRICT	DONNELLY	DRAWN	CJLB 14/06/2018		
LGA	SHIRE OF MANJIMUP	CHECKED	<i>RD 18-7-18</i>		
PLAN REF.	DBCA COG PLAN: 2028-1 & 4 (JB.56)	FILE No.	2013/002765-1		
ORTHO PHOTO	N/A	DATUM	GDA94, MGA Zone 50		

ATTESTATION SHEET

Dated this 24th day of September in the year 2018

LESSOR SIGN HERE

The Common Seal of the CONSERVATION)
AND LAND MANAGEMENT EXECUTIVE)
BODY was hereunto affixed by:)

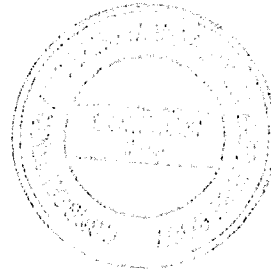

[Signature]
CHIEF EXECUTIVE OFFICER

in the presence of:

[Signature]
Witness Signature

Jane O'Neill
Name of Witness

Public Servant
Occupation of Witness

17 Dick Perry Ave Kensington WA 6151
Address of Witness

LESSEE SIGN HERE

Executed by

[Signature]
John West

[Signature]
Witness Signature

BRUCE CLOUGH
Name of Witness

RETIRED
Occupation of Witness

22 FRENCH ST. PENNANTHILL WA
Address of Witness

Executed by

Leonie West
Leonie West

Bruce Clough
Witness Signature

BRUCE CLOUGH
Name of Witness

RETIRED
Occupation of Witness

22 FRENCH ST PERMBERTON
Address of Witness
WA.

Kevin West
Kevin West

Bruce Clough
Witness Signature

BRUCE CLOUGH
Name of Witness

RETIRED
Occupation of Witness

22 FRENCH ST PERMBERTON
Address of Witness
WA.

